

Aera

Aera® HG200 Series

Pressure Insensitive (PI) Mass Flow Controller

Aera® HC100/HM100 Series

Digital Mass Flow Controller (non-PI) , Mass Flow Meter



Aera

Features

- ▶ Quick flow-response, 0.3s (HG200 series)
- ▶ 10 million cycle life guarantee
- ▶ DeviceNet®, RS-485/analog, EtherCAT®
- ▶ Self-diagnostic / response learning function (HG200 series)



Mass flow controller is one of the most critical devices in semiconductor manufacturing tools, and the MFC performance is progressing in tandem with changes in semiconductor processes. The HG200/HC100/HM100 series is a leading-edge digital MFC/MFM model incorporating proven technologies.

HG200/HC100/HM100 series features improved key performance characteristics in response, reliability, control range, and flow accuracy.

High speed flow-response 0.3s (HG200 series)

Quick response is essential for modern semiconductor processes. The HG200 series uses an enhanced control algorithm to provide excellent response times (0.3 s for Multi-1 to Multi-5 bin sizes).

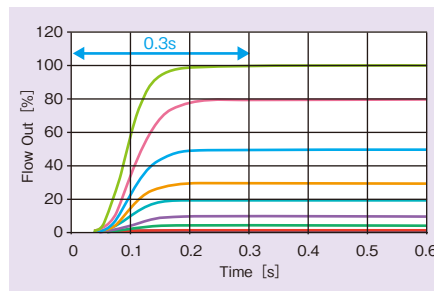

The example of the rising edge in the wave form (Multi-4)

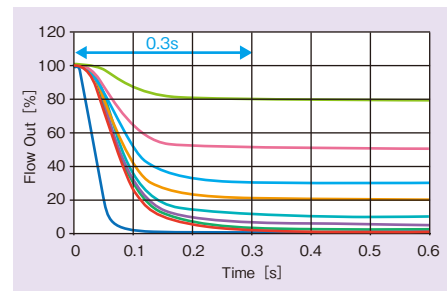

The example of the falling edge in the wave form (Multi-4)

10 million cycle life, robust diaphragm valve

For applications such as ALD with frequent cycle processes, a high cycle life flow control device is critical. The HG200 / HC100 series are designed with an optimized drive circuit, PIEZO valve element, and a Co-Ni alloy diaphragm, achieving 10 million cycle life.

DeviceNet®, RS-485 / analog, EtherCAT®

Analog and digital interfaces such as DeviceNet® and EtherCAT® are available in the HG200 / HC100 series products.

Self-diagnostic / response learning function

A response learning function allows for even finer tuning of the response of each MFC (zero to setpoint), based on the valve-response hysteresis for each MFC. This allows for even more uniform and stable response characteristics. HG200 / HC100 series products also include a self-diagnosis function, with an alarm both visible on the unit and communicated to the tool.

Other Features

- ▶ Multi-gas, Multi-range selection
- ▶ 9 BIN sizes, enabling control from 10 SCCM to 50 SLM
- ▶ High accuracy, $\pm 1\%$ S.P. @10-100% (N₂)
- ▶ Wide flow control range, 0.5-100% F.S. (NC type with PCTFE poppet model)
- ▶ High valve shut-off performance, 0.1% F.S. (NC type with PCTFE poppet model)
- ▶ Wide temperature range 15-50°C
- ▶ RoHS / CE compliant
- ▶ Pressure Insensitive function (HG200 series)

9 BIN size MFCs enable to control from 10SCCM to 50SLM

9 BIN sizes enable control from 10SCCM to 50 SLM with Multi gas, Multi range models. Each Bin size is applicable for a wide flow range, so it is possible to convert a single MFC for a wide range of gasses and flows rather than replacing with another BIN. This provides excellent flexibility on-site.

High accuracy, $\pm 1\%$ S.P. @10 - 100% (N₂)

As opposed to legacy model's control range (25-100% FS), HG200 / HC100 series provides +/- 1% accuracy from 10% to 100% of Full Scale.

Wide flow control range, 0.5 - 100% F.S.

HG200 / HC100 provide a very wide flow range of 0.5 – 100% F.S. (NC type with PCTFE poppet model), as opposed to the legacy model, with 2 – 100% F.S. This provides even further flexibility to cover multiple flow needs with one MFC.

Electrical Connection

Analog model 9Pin D-sub male type (M3 screw)

1	VALVE OPEN / CLOSE (except HM100 / HM101) Connect to +15V : OPEN Connect to -15V : CLOSE
2	OUTPUT (0 - 5VDC / 0 - 100%F.S.)
3	INPUT POWER (+15VDC)
4	POWER COMMON
5	INPUT POWER (-15VDC)
6	SET POINT INPUT (except HM100 / HM101) (0 - 5VDC / 0 - 100%F.S.)
7	SIGNAL COMMON
8	SIGNAL COMMON
9	VALVE voltage output (0 - 4V / 0 - 100%) (except HM100 / HM101)

RS485 model 9Pin D-sub male type (M3 screw)

1	NA
2	NA
3	INPUT POWER (+15VDC)
4	POWER COMMON
5	INPUT POWER (-15VDC)
6	NA
7	SIGNAL COMMON
8	RS485+
9	RS485-

Leak across the valve 0.1% F.S.

“Bursting” is a condition resulting from a buildup of gas between the MFC control valve and the downstream valve when both are closed. In order to minimize this phenomenon, HG200 / HC100 is designed to minimize the leak by across the MFC valve. While the MFC is not an inherently full close valve, the very low leak by of 0.1% F.S. in the HG200 / HC100 series (NC type / PCTFE poppet model) reduces the likelihood of “bursting.”

Wide temperature range 15 – 50°C

This product is equipped with high-quality components, and is capable of operating in high temperatures often seen in gas boxes, up to 50°C.

RoHS / CE compliant

This product is EU-RoHS and CE marking compliant.

Pressure Insensitive function (HG200 series)

The Pressure Insensitive function within the HG200 series enables stable flow control despite pressure fluctuations upstream or downstream of the MFC.

DeviceNet® model CM02-8DR5P-CF (D5) DDK

1	SHIELD
2	INPUT POWER (+11 - 25VDC)
3	GND (-)
4	CAN (H)
5	CAN (L)

EtherCAT® model (Power connector)

1	+24VDC
2	FG
3	POWER COMMON (0V)

EtherCAT® model (Communication connector) Cat.5 RJ45 Ethernet connector

Category 5 networking Ethernet cable is used.

Specification

Items	HG200 / HC100 / HM100	HG201 / HC101 / HM101	
Full-Scale Range (N ₂ equivalent flow)	10-5,000SCCM (Multi-1-6)	5,001-10,000SCCM (Multi-7)	10,001-50,000SCCM (Multi-8, 9)
Flow Sensing	Thermal Sensor Type		
Flow Calibration	Multi Gas, Multi Range (9 BINS)		
Settling Time (SEMI [™] E17-91) ^{※2}	HG200 / HG201: < 0.3s (Multi-1-5), < 0.5s (Multi-6, 7) HC100 / HC101: < 1.0s (Multi-1-7)		HG201: < 0.7s (Multi-8, 9) HC101: < 1.0s (Multi-8, 9)
Accuracy (N ₂) ^{※3}	< ±1% S.P. (10 - 100%), < ±0.1% F.S. (2 - 10%)		
Linearity	< ±0.5% F.S.		
Repeatability	< ±0.2% F.S.		
Zero Stability	< ±0.3% F.S. / year		
Leak Integrity	< 1x10 ⁻¹¹ Pa·m ³ /s (He)		
Flow control range ^{※4} (except HM100 / HM101)	0.5 - 100% F.S. (PCTFE poppet model), 2 - 100% F.S. (Metal poppet, Normally-Opened model)		
Operating Pressure Range ^{※5}	50 - 400kPaD (Multi-1-6)	70 - 400kPaD (Multi-7)	250 - 400kPaD (Multi-8, 9)
Operating Pressure Range (HM100 / HM101)	20kPaD		
Maximum Operating Upstream Pressure	400kPaG		
Operating Downstream Pressure Range	Vacuum to atmospheric pressure		
Leak Across Valve (except HM100 / HM101)	< 0.1% F.S. (PCTFE poppet), < 1.0% F.S. (Metal poppet, Normally-Opened model) [N ₂ P1=50kPaG (Multi-1-6), 70kPaG (Multi-7), 250kPaG (Multi-8, 9), P2=atmospheric pressure]		
Proof pressure	HG200 / HG201: 0.6MPaG, HC100 / HC101/ HM100 / HM101: 1MPaG		
Ambient Temp. Range	15 - 50°C [Gas temperature needs to be equal to ambient temperature]		
Internal pressure sensor accuracy (HG200 / HG201)	< ±5kPa [0 - 500kPa (abs)]		
Internal temp. sensor accuracy (HG200 / HG201)	< ±1°C [15 - 50°C]		
Control Valve Type (except HM100 / HM101)	Normally-Closed (NC) and Normally-Opened (NO) Piezo Valve		
Materials for external seals	316L Stainless Steel		
Gas wetted materials	Normally-Closed: 316L Stainless Steel, (PCTFE), Co-Ni alloy Normally-Opened: 316L Stainless Steel, Co-Ni alloy		
Fittings	92mm 1.125" Cseal, 92mm 1.125" Wseal [®] , 124mm 1/4" VCR [®] type		
Surface Finish	Electro-polished (fitting, sensor, base) Ra=0.2μm, machine finish Ra=0.8μm		
Orientation	Any position		
Mass	1.1kg		
Special functions	Pressure Insensitive function (HG200 / HG201 series) microSD [™] card, LCD Display to monitor various parameters (HG200 / HG201 series)		
Signal interface	Analog, Digital (RS485, DeviceNet [®] , EtherCAT [®])		
Connector type	Analog : 9Pin D-sub Digital : RS485, DeviceNet [®] , EtherCAT [®] Maintenance : RS485/Φ2.5 3-pole round connector (for all model)		
Input power ^{※1}	Analog : +15VDC ±4% 90mA, -15VDC ±4% 60mA DeviceNet [®] : +11VDC 150mA - +25VDC 90mA EtherCAT [®] : +24VDC ±10% 120mA		
Flow set signal (Analog model, except HM100 / HM101)	0 - 5VDC / 0 - 100% F.S. input impedance > 1MΩ		
Flow out signal (Analog model)	0 - 5VDC / 0 - 100% F.S. load impedance > 2kΩ		

※1. This specification is defined based on our standard test conditions with single MFC. Performance under different conditions may not satisfy this specification, and we do not guarantee this specification under all possible configurations.

※2. From 0% to 5% S.P. or greater, ambient temperature is 22°C (Min. 15°C, Max. 32°C)

※3. Digital mode, ambient temperature is 22°C ±3°C

※4. Valve closes if the set point applied is less than 0.5% F.S.

※5. For N₂ full-scale flow where outlet pressure is less than half of inlet pressure minus 13.8 kPaA.

"SCCM" and "SLM" indicate the gas flow given in mL/min and L/min, at 0°C and 101.3kPa(abs) conditions. F.S.=full scale S.P.=set point

Dimensions

1.125" IGS® fitting

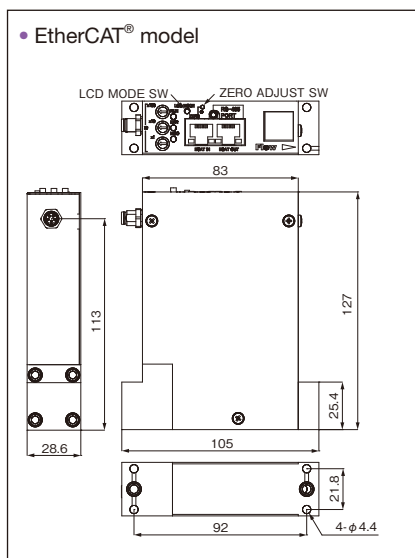
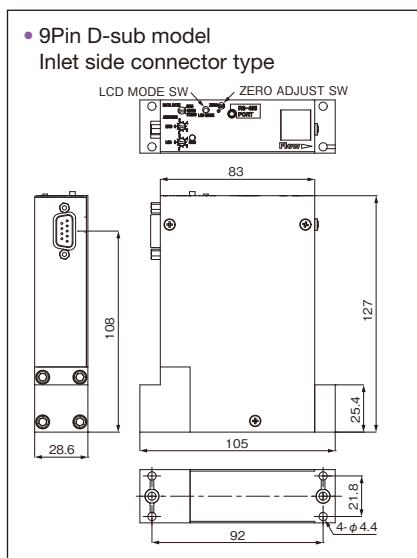
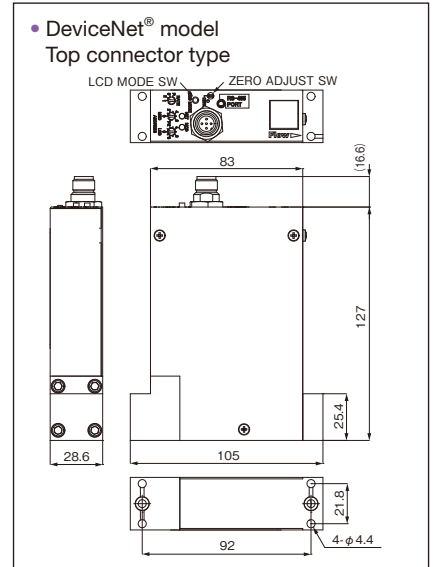
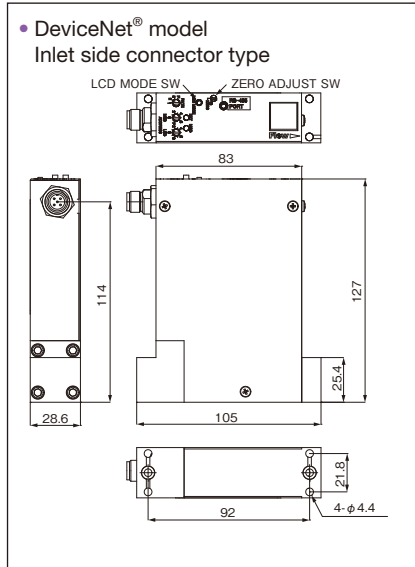
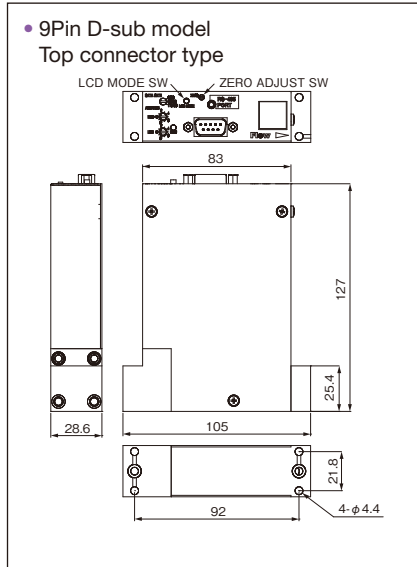

124mm 1/4" VCR® type fitting

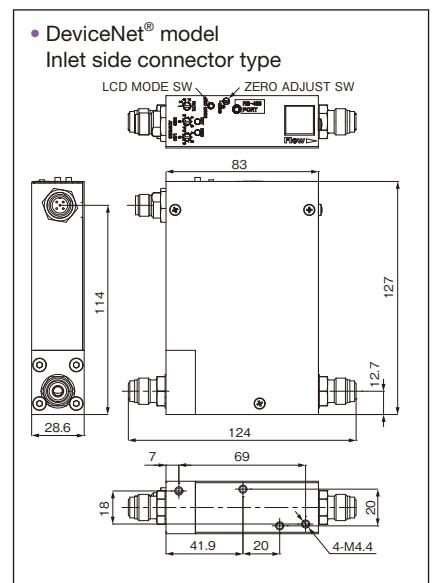
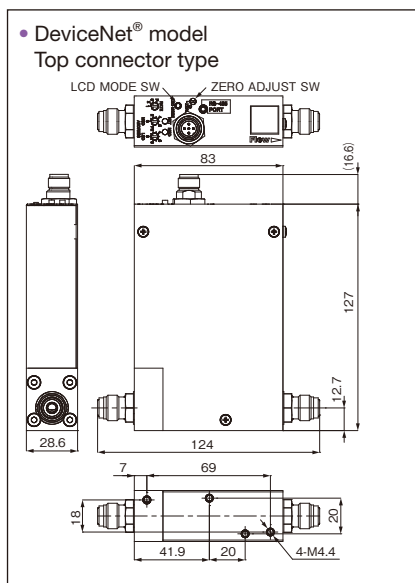
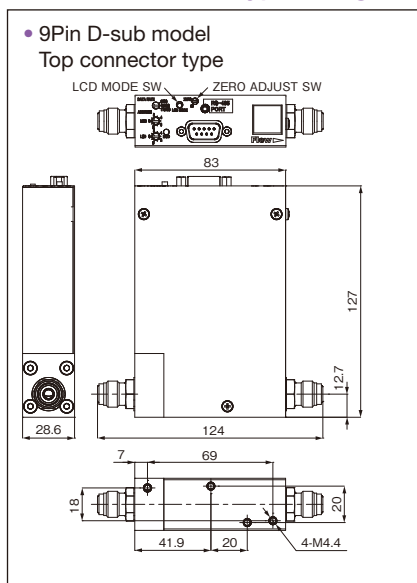

HG200 / 201, HC100 / 101, HM100 / 101 series model and suffix codes

Category	Description		Suffix codes							
Model	Thermal sensor type	PI-MFC	HG200							
			HG201							
		Non-PI-MFC	HC100							
			HC101							
		MFM	HM100							
		HM101								
Communication interface	Analog (9Pin D-sub)			A						
	DeviceNet®			D						
	L Protocol RS485 (9Pin D-sub)			L						
	Aera RS485 (9Pin D-sub)			R						
	EtherCAT®			E						
Communication connector location	Top (except L Protocol RS485 model)			T						
	Inlet side (except EtherCAT® model)			U						
External seals	Metal seal				M					
Valve type	Normally-Closed					C				
	Normally-Opened					O				
Fitting	92mm 1.125" Wseal®						BW1			
	92mm 1.125" Cseal						BA1			
	124mm 1/4" VCR® type						4V2			
Fixed code							1			
Optional code	No option							NNN		
	Metal poppet							ANN		
Full scale range	10 to 30 SCCM							Multi -1		
	31 to 100 SCCM							Multi -2		
	101 to 300 SCCM							Multi -3		
	301 to 1,000 SCCM							Multi -4		
	1,001 to 3,000 SCCM							Multi -5		
	3,001 to 5,000 SCCM							Multi -6		
	5,001 to 10,000 SCCM							Multi -7		
	10,001 to 30,000 SCCM							Multi -8		
	30,001 to 50,000 SCCM							Multi -9		
Example	HG200DTMCBA11NNN Multi-5									
	Thermal type PI-MFC, DeviceNet®, Top connector, Metal seals, Normally-Closed Piezo valve, 1.125" 92mm Cseal fitting, No option, full-scale 3000SCCM									

Proterial, Ltd.

<https://www.proterial.com/e>

Headquarters

Piping Components Business Unit
Fine Flow Dept.
Toyosu Prime Square, 5-6-36 Toyosu, Koto-ku, Tokyo 135-0061, Japan
Tel +81-(0)50-3664-9511 Fax +81-294-87-7147

Proterial America, Ltd.

San Jose Office

2570 N. First Street, Suite 200, San Jose, California 95131, U.S.A.
Tel +1-408-467-8900 Fax +1-408-467-8901
E-mail : aerasales@us.proterial.com

Proterial (China), Ltd.

<https://www.china.proterial.com>

Room 1501, T1 of Raffles City, No.1133, Changning Road, Shanghai, 200051, P.R.China
TEL: +86-(0)21-3366-3000

Call Center

TEL: + 86-(0)755-8600-6828 ext: 885
+ 86-(0)138-0989-5542

Email: service@proterial.com

Proterial Europe GmbH

Immermannstrasse 14-16, 40210 Duesseldorf, Germany
Tel +49-211-16009-0 Fax +49-211-16009-29
E-mail : aerasales-europe@eu.proterial.com



Safety Precaution

Before using any of the products introduced in this catalog, please read the respective user manuals thoroughly.

- Contents of this catalog are as of May 2023.
- The products and their specifications are subject to change without notice. Please check the latest catalog, technical documents or specifications before your final design, procurement or use of the products.
- Aera® is a registered trademark of Proterial, Ltd.
- DeviceNet® is a registered trademark of Open Device Net Vendor Association, Inc. (ODVA).
- VCR® is a registered trademark of Swagelok Company.
- IGS® and Wseal® are registered trademarks of Fujikin Incorporated.
- SEMI™ is a trademark or registered trademark of Semiconductor Equipment and Materials International in the United States.
- microSD™ is a trademark or registered trademark of SD Card Association.
- EtherCAT® is a registered trademark and patented technology, licensed by Beckhoff Automation GmbH, Germany.

EtherCAT

We are not liable for and do not accept responsibility for any loss, direct or indirect, caused by incorrect use, careless handling, force majeure, war, terrorism, fire, pollution, use in unapproved environments, salt damage, or any natural disasters (such as wind or flood damage, earthquakes or lightning), or for any consequential damage.